



**DRAFT DESIGN REQUIREMENTS  
DOCUMENT**

**FOR**

**SECONDARY AND TERTIARY COATING  
PLANT**

TMT.OPT.DRD.09.004.DRF01

September 18, 2009



## TABLE OF CONTENTS

<b>1. INTRODUCTION</b>	<b>5</b>
1.1 Introduction .....	5
1.2 Purpose.....	5
1.3 Scope.....	5
1.4 Applicable Documents .....	6
1.5 Reference Documents .....	6
1.6 Change Record .....	7
1.7 Abbreviations .....	7
<b>2. OVERALL DESCRIPTION</b>	<b>8</b>
2.1 Perspective .....	8
2.1.1 Telescope M2 and M3 Size and Optical Prescription .....	9
2.1.2 M2 and M3 Maintenance.....	10
2.1.3 M2 and M3 Coating Plant Mirror Fixtures and Loader .....	10
2.1.4 TMT Mirror Coating Laboratory.....	11
2.1.5 Baseline Coating Requirements .....	12
2.1.6 Future Coating Development .....	13
2.1.7 Proposed M2/M3 Coating Plant Architecture .....	13
2.2 System Functions .....	14
2.3 User and Operator Characteristics.....	14
2.4 External Interfaces.....	14
2.5 Constraints.....	15
2.6 Assumptions and Dependencies.....	16
<b>3. SPECIFIC REQUIREMENTS</b>	<b>17</b>
3.1 General Constraints .....	17
3.2 Environmental Constraints.....	17
3.3 Functional Requirements .....	17
3.3.1 Coating Chamber Requirements .....	17
3.3.2 M2 and M3 Coating Fixture Requirements.....	18
3.3.3 Coating Plant Controls Requirements .....	18
3.3.4 Coating Plant Software Requirements.....	18
3.3.5 Process Throughput .....	18
3.4 Coating Performance Requirements.....	19
3.5 System Attributes .....	19
3.5.1 Reliability .....	19
3.5.2 Availability.....	20
3.5.3 Safety and Security.....	20
3.5.4 Maintainability.....	20
3.5.5 Seismic Safety .....	20
<b>APPENDIX</b>	<b>22</b>
<b>I. REQUIREMENTS FOR REFLECTIVE OPTICAL COATINGS, FROM RD2</b>	<b>22</b>
a. Performance Requirements.....	22



---

i.	Reflectivity Requirements .....	22
ii.	Emissivity Requirements.....	23
iii.	Change of reflectivity with wavelength .....	23
iv.	Polarization .....	23
v.	Coating thickness uniformity .....	23
vi.	Coating-induced deformation of optical surface .....	24
vii.	Coating process constraints .....	25
viii.	Coating Durability .....	25
b.	Environmental, Chemical and Physical Constraints .....	25
i.	Coating Visual Inspection .....	25
ii.	Environmental, Chemical and Physical Testing.....	26
iii.	Maintainability .....	26
iv.	Safety and Health.....	27

**TABLE OF FIGURES**

Figure 3. Telescope Optical Design ..... 10  
 Figure 4. TMT Mirror Coating Laboratory..... 11

**LIST OF TABLES**

Table 1. Dimensions and Optical Parameters of the TMT M2 and M3 .....9  
 Table 2. Minimum reflectivity as a function of wavelength for fresh coatings..... 12  
 Table 3. Layers of the protected silver Gemini coating ..... 12  
 Table 4. Environmental, Chemical and Durability Testing of the Optical Coating.....**Error! Bookmark not defined.**  
 Table 5. Coating Plant Facilities Interface Definition ..... 19  
 Table 2. Minimum reflectivity as a function of wavelength for fresh coatings at the prescribed angles of incidence shown in Table 3. .... 22  
 Table 3. Range of angles of incidence for reflection at each mirror surface. .... 23  
 Table 4. Environmental, Chemical and Durability Testing of the Optical Coating..... 26

## 1. INTRODUCTION

### 1.1 INTRODUCTION

This design requirements document (DRD) contains requirements for the optical coating plant that will deposit coatings on the Secondary (M2) and Tertiary (M3) mirrors of the Thirty Meter Telescope (TMT). The requirements for the coatings that are to be deposited are described in the reference document **TMT DRD for Telescope Optical Coatings** (RD1). A portion of RD1 is provided within this document in Appendix I.

This document captures requirements specified in the top level requirements documents, Observatory Architecture Document (OAD), Observatory Requirements Document (ORD), Operations Concept Document (OCD), and system engineering error budgets and provides flow down and interpretation at the level of the M2 and M3 optical coating plant. Also included are requirements that originate at the level of this document.

Where the requirements from any applicable or reference documents such as AD1, AD2, AD3, or RD1) are listed herein, they retain their original requirement numbering configuration and are duplicated here verbatim. Specific requirements that originate within this document are assigned requirement numbers within this document.

### 1.2 PURPOSE

This document is intended to describe requirements for the coating plant that will be used to apply optical coatings to the telescope M2 and M3 mirrors at first light; and additionally, to describe requirements for feasible future upgrades to the coating plant that would enable the application of enhanced coatings that would meet desired science goals.

The document will guide the design and verification of the coating plant used to apply first light optical coatings for the M2 and M3 mirrors during the design and construction phase of the TMT Observatory. The coating plant specified herein also will periodically apply new coatings to M2 and M3 after the previous coating has been stripped from the mirror surface. Attention to requirements for future upgraded coatings will ensure that the future upgrade will be feasible.

### 1.3 SCOPE

This document describes the constraints and functional performance requirements of the M2/M3 Coating Plant, which is a major portion of the M2/M3 Coating Equipment work breakdown structure (WBS) element, TMT.TEL.OPT.COAT.M2M3. The position of this element in the WBS is illustrated in Figure 1.

Included in this document are the requirements for the optical coating plant that will apply coatings to M2 and M3. The coating plant includes a coating chamber assembly that is large enough to accommodate the variation in size and shape of both mirrors; ports as needed for vacuum control and source supply; coating fixtures that hold and protect the mirrors while being transferred from the mirror coating carts into the coating chamber, and hold the mirrors in the chamber; a loader to provide controlled entry into the chamber; a sealed entry port; the vacuum control system including pumps, valves and sensors; the source supply system including reaction materials, energizing method, carrier gases, cabinets and control valves; heaters and cooling

systems as required; source supply control hardware such as Mass Flow Controllers, valves and sensors; control electronics; and control software with a user-friendly interface that provides both local control and remote access. An interlocked safety system with Emergency Off Switch, sensors, venting and safe shutdown controls that engage during power loss conditions or hardware failure conditions shall also be implemented to meet safety regulations that apply on Mauna Kea.

Requirements for the coating itself are detailed in RD2, TMT DRD for Telescope Optical Coatings. For coating specification details, RD2 will take precedence.

Not included are requirements for the coating plant that will apply coatings to the telescope primary mirror segments or the instrument optical surfaces which are specified in a separate requirements documents.

Not included are all handling equipment required to safely remove, process, and reinstall M2 and M3 from the telescope, transport the mirrors, disassemble and reassemble the mirror cells, transfer and support M2 and M3 as they travel to and from the mirror stripping area and are cleaned and stripped, and transfer, to and from the coating plant for loading and unloading.

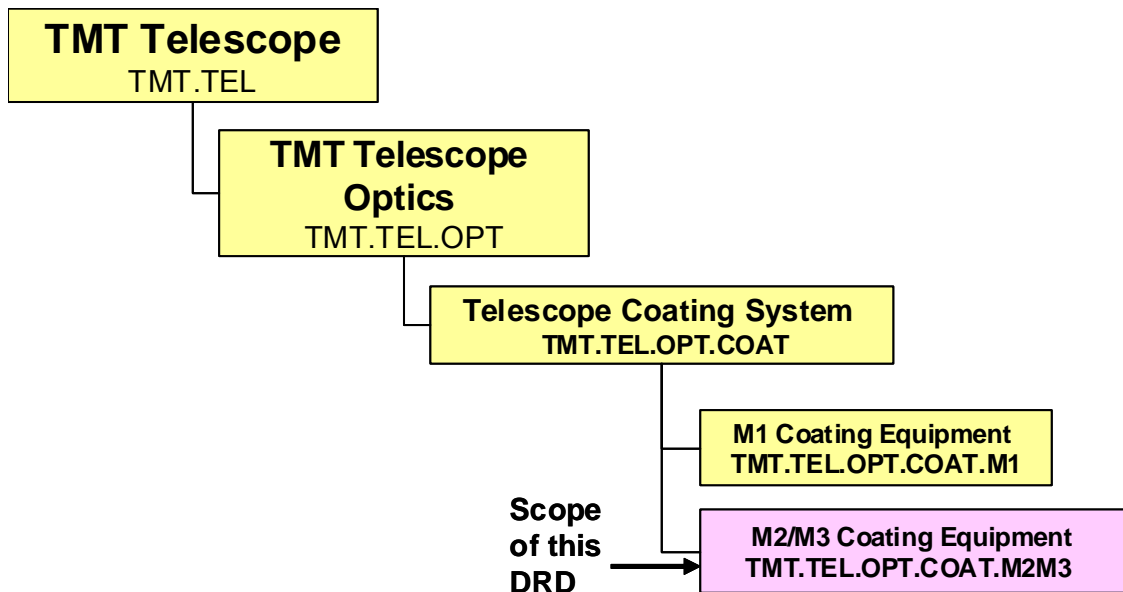

Figure 1. Work Breakdown Structure Element Covered by This Requirements Document

#### 1.4 APPLICABLE DOCUMENTS

- AD1 [Operations Concept Document \(OCD\)](#), (TMT.OPS.MGT.07.002)
- AD2 [Observatory Requirements Document](#), (TMT.SEN.DRD.05.001)
- AD3 [Observatory Architecture Document](#), (TMT.SEN.DRD.05.002)

#### 1.5 REFERENCE DOCUMENTS

- RD1 [DRD for Telescope Optical Coatings](#) (TMT.OPT.DRD.09.003)

- RD2 [Ritchey-Chrétien Baseline Design](#) (TMT.SEN.SPE.06.001)
- RD3 [TMT Coating System Requirements](#) (TMT.OPT.SPE.06.003)
- RD4 [Baseline Optical Design of the Thirty Meter Telescope](#) (TMT.SEN.TEC.05.002)
- RD5 [DRD for Secondary Mirror System](#) (TMT.OPT.DRD.07.004)
- RD6 [DRD for Tertiary Mirror System](#) (TMT.OPT.DRD.07.006)
- RD7 [Interface Control Document, M2 to Coating Plant](#) (TMT.SEN.ICD.07.004)
- RD8 [Interface Control Document, M3 to Coating Plant](#) (TMT.SEN.ICD.07.015)
- RD9 Interface Control Document, TMT Observatory Facility and M2/M3 Coating Plant
- RD10 [Coating the 8-m Gemini telescopes with protected silver](#) (TMT.OPT.JOU.0.005)
- RD11 [Coating Considerations](#) (TMT.OPT.TEC.08.215)
- RD12 [TMT Power Usage and Heat Dissipation Budgets](#) (TMT.SEN.TEC.08.054)

## 1.6 CHANGE RECORD

Revision	Date	Section	Modifications
DRF01	09/01/2009	All	Initial draft

## 1.7 ABBREVIATIONS

- AIV** – Alignment, Integration and Verification
- EMI** – Electromagnetic Interference
- FOV** – Field of View
- CLN** – Optical Cleaning System
- COAT** – Optical Coating System
- CTE** – Coefficient of Thermal Expansion
- HNDL** – Optical Handling System
- M1** – Telescope Primary Mirror
- M2** – Telescope Secondary Mirror
- M3** – Telescope Tertiary Mirror
- MFC** – Mass Flow Controller
- OAD** – Observatory Architecture Document
- ORD** – Observatory Requirements Document

**OCD** – Operations Concept Document

**REQ** – Requirements

**SPR** – Surface Plasmon Resonance

**TMT** – Thirty Meter Telescope

**Ø** – diameter

Units:

**as** – arcsecond

**Hz** – Hertz

**K** – Kelvin

**m** – meter

**mas** – milliarcsecond

**MFC** – Mass Flow Controller

**mm** – millimeter

**MPa** – megapascal

**nm** – nanometer

**N-m** – Newton-meter

**Pa** – Pascal

**W** – Watt

**µm** – micrometer

## 2. OVERALL DESCRIPTION

### 2.1 PERSPECTIVE

The Thirty Meter Telescope is a three mirror design configured as shown in Figure 2. All three telescope mirrors consist of active optical assemblies with thin mirror elements made of low expansion glass or glass ceramic. The Secondary Mirror (M2) and Tertiary Mirror (M3) are both mounted in actuated mirror cells with both lateral and axial attachments.

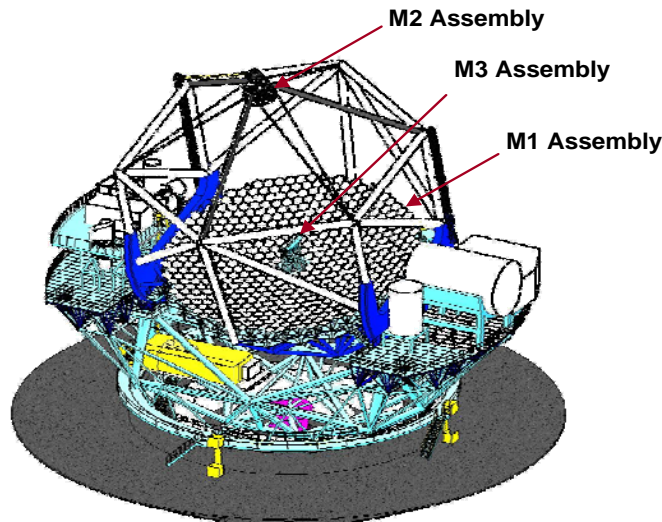

Figure 2. Thirty Meter Telescope

### 2.1.1 Telescope M2 and M3 Size and Optical Prescription

Both M2 and M3 are low expansion glass or glass ceramic elements. M2 is a convex asphere, and M3 is flat. The outer dimensions, thicknesses and optical parameters of M2 and M3 are shown in Table 1. The mass of the M2 mirror (with invar attachment pucks) will not exceed 2,230 kg. The mass of the M3 mirror (with invar attachment pucks) will not exceed 2015 kg. The full telescope optical design shall be a Ritchey Chrétien configuration as described in REQ-1-OAD-1000 of AD2. A layout of the optical design is shown in Figure 3 (from AD2). Full descriptions of the M2 and M3 Mirror cells are included in RD7 and RD8.

Table 1. Dimensions and Optical Parameters of the TMT M2 and M3

Mirror Element	Optical Surface Size and Shape	Coated Clear Aperture	Thickness	Radius of Curvature	Conic Constant
M2	Circular 3.120 m diameter	Circular >3.060 m diameter	100 mm	- 60.0	- 1.00095
M1	Elliptical, long axis 3.530 m short axis 2.514 m	Elliptical, long axis >3.508 m short axis >2.446 m	100 mm	$\infty$	N/A

\*Sign convention: positive curvature is convex toward the sky  
 \*\* Extracted from RD2

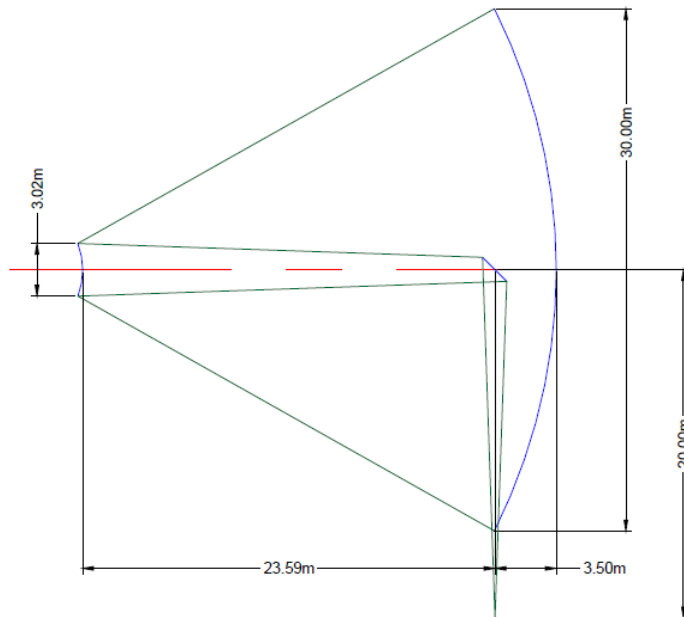

Figure 3. Telescope Optical Design

### 2.1.2 M2 and M3 Maintenance

M2 and M3 mirror surfaces will be cleaned frequently while mounted on the telescope using CO<sub>2</sub> snow. The mirror surfaces will also be washed using fluids. The coating must resist corrosion from the environment, and from washing and be hard enough so that dust and particles will not imbed in nor scratch the surface.

Each mirror will be recoated every two years, so the coatings must be durable enough to last 24 months or longer. The coatings also must be strippable so that the entire previous coating can be removed prior to re-applying the new coating, without damaging the polished surface of the segment.

The full recoating process of removing M2 or M3 from the telescope, carrying the mirror to the coating laboratory, removing the mirror from the mirror cell, stripping the old coating from the mirror surface, loading the mirror into the coating plant, coating the mirror, unloading the mirror from the coating plant, reassembling the mirror cell, transporting the mirror to the telescope, and reassembling the mirror on the telescope shall take no longer than one week.

### 2.1.3 M2 and M3 Coating Plant Mirror Fixtures and Loader

The coating plant shall include fixtures for each mirror that interface with the coating plant loader. The fixture for each mirror will accept the weight of the mirror from the handling equipment, safely support the mirror and interface with the coating plant loader. The loader will be common for both M2 and M3, will be an integral part of the coating plant, and shall smoothly carry the mirrors into and out of the coating plant.

To ensure a smooth coated finish with no particulates embedded in the coating, the mirrors shall be held facing downwards during coating. It also may be required to rotate the mirrors during the coating process to ensure uniform coating layer deposition. The rotation function may be incorporated in the mirror fixture or the loader hardware.

The M2 and M3 mirrors are attached to support cells containing axial and lateral actuators that adjust and correct the mirror surface figure. The actuators are attached to the mirrors through

invar pucks which are bonded to the mirror substrates using epoxy adhesive. The coating plant mirror fixtures may interface with the invar pucks.

### 2.1.4 TMT Mirror Coating Laboratory

Because the telescope mirrors are exposed to the summit environment, they must be recoated approximately every 2 years to maintain telescope performance. Due to the difficulty and risks of transporting the large M2 and M3, the coating plants for the telescope mirrors may be located at the TMT Summit Facility at an elevation of ~4200 meters in the TMT mirror coating laboratory.

The TMT mirror coating laboratory will contain two coating plants: one for coating M1 segments and another for coating M2 and M3. The coating plants will never be operated at the same time.

The mirror coating laboratory will have two areas: a staging area which is a class 10,000 clean room where mirrors will be loaded into and out of the coating chamber; and a Service Area behind the clean room that houses the remaining portions of the coating plant that do not need to be located within the clean room. A sealed partition between the clean room area and the Service Area will prevent air and dust from entering the clean room area. The partition will be designed to mate with the coating plants so that mirrors can be loaded into the coating chamber from the clean room side. A preliminary sketch of the mirror coating laboratory configuration is shown in Figure 4.

The ceiling height of the coating laboratory will be 4 meters minimum. During AIV, a section of exterior wall will be temporarily removed from the building allowing installation of the coating plants. Adjacent to the coating laboratory will be a room for housing the coating plant compressors, cryopumps and roughing pumps, power distribution equipment, gas supplies and other related equipment.. A bridge crane will be located in the clean room area, and is available for mirror assembly handling and coating plant functions if required. Another bridge crane is located in the Service Area (TBC) to facilitate maintenance of the coating plants.

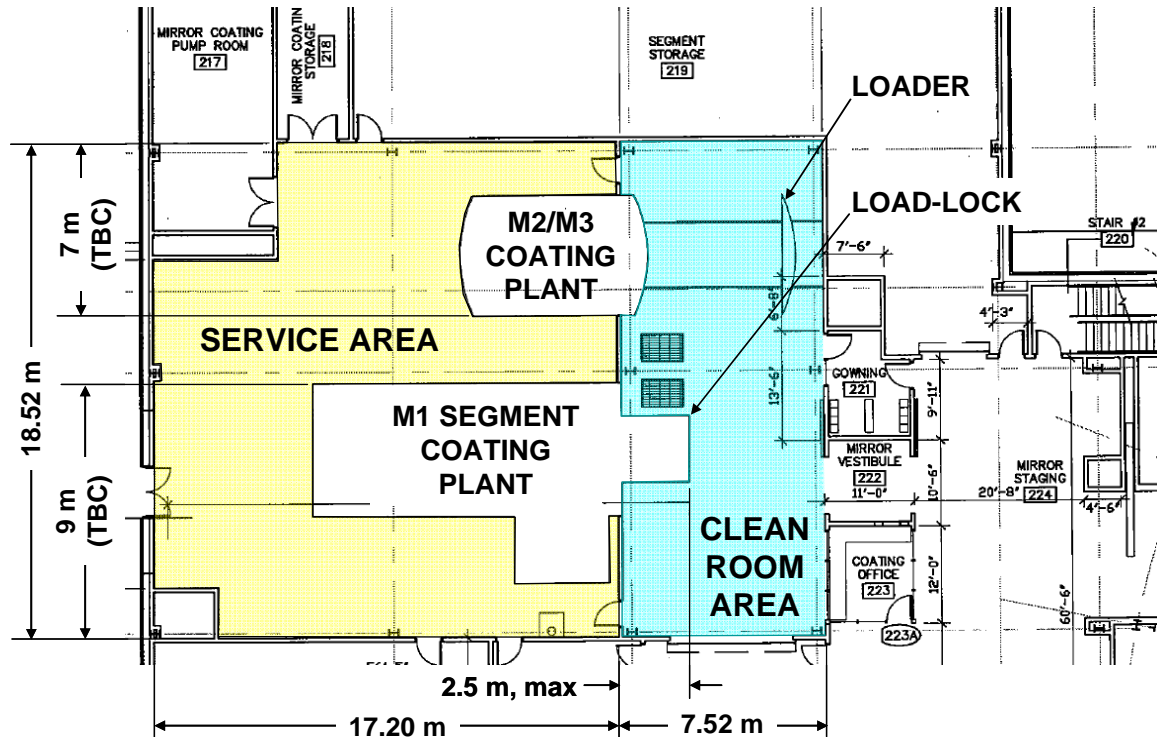

Figure 4. TMT Mirror Coating Laboratory

### 2.1.5 Baseline Coating Requirements

TMT has determined that for the first light coating on the telescope optics will be based on the four layer protected silver coating used on the Gemini telescopes. This coating is regularly applied at both Gemini Observatories using DC magnetron sputtering deposition. In addition, a similar coating has been successfully implemented on the Kepler Space Telescope primary mirror using an ion assisted evaporative coating process. The Gemini coating meets the minimum durability requirements for the TMT optics, but will require additional development and modification in order to meet the future reflectivity and durability goals of the TMT. For first light, though; this coating will be applied. Additionally, this coating may be the baseline from which an enhanced coating will be developed in the future.

From RD1, the first-light reflectivity requirement of the coating is given in Table 2.

Table 2. Minimum reflectivity as a function of wavelength for fresh coatings

Wavelength Range	Requirement	Goal
0.31 - 0.34 $\mu\text{m}$	N/A	0.8
0.34 - 0.36 $\mu\text{m}$	0.8	0.9
0.36 - 0.40 $\mu\text{m}$	0.8 $\rightarrow$ 0.9	0.9 $\rightarrow$ 0.95
0.4 - 0.5 $\mu\text{m}$	0.9 $\rightarrow$ 0.95	0.95 $\rightarrow$ 0.98
0.5 - 0.7 $\mu\text{m}$	0.95 $\rightarrow$ 0.97	0.98
0.7 - 1.8	0.97	0.98
1.8 - 28 $\mu\text{m}$	0.985	0.987
The arrow represents linear reflectivity change between the values shown over the given wavelength range.		

From RD10, the Gemini coating consists of the following layers:

Table 3. Layers of the protected silver Gemini coating

Material	Function	Thickness	Thickness tolerance
$\text{SiN}_x$	protector	15 nm	TBD
$\text{NiCrN}_x$	adhesor	0.8 nm	TBD
Ag	reflector	200 nm	TBD
$\text{NiCrN}_x$	adhesor	5 nm	TBD
substrate			

Additional features of this coating are that robust deposition of the nitride layers is sensitive to the presence of  $\text{H}_2\text{O}$ , so having the capability to achieve  $10^{-7}$  torr pressure to remove all  $\text{H}_2\text{O}$  molecules prior to nitride deposition improves the quality of these layers. Also, the coating reflectivity versus wavelength is very sensitive to the thickness of the two outer nitride layers.

Also, it is important to note that the silver layer must be dense and small grained. Surface Plasmon Resonance (SPR) within silver produces significant absorption in UV/blue wavelengths when the roughness or grain size of the silver is too large. To prevent this, the silver should be deposited rapidly on a cold substrate, thus forming dense small grains and minimizing SPR response.

In summary, the TMT coatings must meet the following general constraints:

- Coatings must be efficient for science:

- Must be highly reflective
  - Must work over a wide wavelength range (0.31 – 28  $\mu\text{m}$ ).
  - Must have low IR emissivity (i.e., reflectance in IR must be high)
- Reflectance shall vary slowly with wavelength to enable data interpretation
- Coating must work at a range of incidence angles.
- Coating must have excellent longevity to reduce operation costs and risks:
  - Recoating is planned every two years, but involves risk and telescope downtime. Longer lasting coatings will significantly reduce cost.
  - Risk of damage to mirrors increases with frequency of removal, stripping, coating and reinserting. Less frequent recoating will significantly reduce risk.
  - Coating should be easily strippable with no resultant damage to the optical substrate.
- Coating must be mechanically robust to withstand ~2-10 yrs regular cleaning with CO<sub>2</sub> snow and washing.
  - Coating should adhere well to substrate
  - Coating shall not be soft
  - Coating must not react or corrode when exposed to CO<sub>2</sub> or the fluids used for washing.
- Stress should be low (or predictable):
  - With thin substrates, stress induced between the coating and the mirror element can deform the optical figure.
  - Non-uniformity or non-repeatability in the resulting stress may deform the optical figure in a manner that is not be fully compensated using the adaptive actuators for each element.
- Coating shall be uniform
  - Thickness shall be uniform so that the mirror surface figures are unchanged due to dimensional variation or by stress variation
  - Reflectivity shall be uniform across the clear aperture of the coated mirror.

### 2.1.6 Future Coating Development

Because silver is the only metal that meets TMT reflectivity requirement goals over most of the TMT wavelength range (RD11), it is assumed that future coating development will use silver for the primary reflecting material. Silver adheres poorly to glass requiring an adhesion layer, needs protection to prevent tarnishing, and requires enhancement in the UV to meet reflectivity goals.

The materials that will be used to enhance the TMT mirror coatings are not determined yet. Early studies described in RD11 have indicated that a possible substitute for the Gemini undercoat of NiCrN might be based on Yttrium oxide with both good adhesion to silver and solubility in dilute acids so that the coating can be stripped. Possible substitutes for the Gemini protection layers may be oxides and nitrides based on Si, Hf, Ta, Zr, Y, Sc, Nb, Gd, and Ti. This list of materials is not intended to be complete.

### 2.1.7 Proposed M2/M3 Coating Plant Architecture

Preliminary coating plant studies have developed a possible M2/M3 coating plant architecture that accommodates the variation in surface profiles and sizes of M2 and M3. In the possible coating chamber, the M2 and M3 mirrors rotate facing downwards towards the deposition sources below. The separation distance between the deposition source and the mirror surface must be controlled to produce high quality coatings on a variety of mirror sizes with controlled layer thickness and uniformity. Provisions are needed to measure physical film thickness. Deposition source hardware shall be provided as necessary to direct the deposition angles to create high quality coatings.

The deposition sources that will be provided for the initial deposition of the first light coating will be selected to provide the 4-layer protected silver Gemini coating. It may be necessary to

incorporate additional capabilities into the plant to achieve greater thickness control for deposition of the required nitride layers. The chamber shall include ports and required features for adding additional deposition sources that can be used in the future to include additional materials that will enhance the reflectivity and performance of the coating.

The possible M2/M3 coating plant could be a horizontally oriented vacuum chamber large enough to fit the rotating M3, loaded from one end using a sliding loader. The loading port would open into a clean room where the mirrors would be prepared for coating in a dust-free environment.

Preparation for coating M2 or M3 may require extensive chamber cleaning to remove deposits from previous coating runs. During coating deposition, the possible coating steps for depositing the 4-layer protected silver Gemini coating may be required:

- Load the mirror and close and seal the loading port
- Pump down to  $< 3 \times 10^{-7}$  torr
- Heat to 80°C, plasma clean
- Deposit layer 1, NiCrN<sub>x</sub>
- Deposit layer 2, Ag
- Deposit layer 3, NiCrN<sub>x</sub>
- Deposit layer 4, SiN<sub>x</sub>
- Bring to atmospheric pressure, open the loading port and unload the mirror

## 2.2 SYSTEM FUNCTIONS

The coating plant for M2 and M3 must deposit coatings that meet the requirements of RD2 including high reflectivity across a broad wavelength range, environmental durability, and uniform thickness with film stress that is low and uniform. The coatings must survive frequent cleaning with CO<sub>2</sub> snow and fluids and must also be strippable without damage to the substrate so that the substrates may be periodically recoated to recover full performance.

The coating plant must be designed for depositing high quality coatings to two differently sized mirrors with different mirror surface figures.

The coating plant must have the ability to be upgraded to enable coating with additional material layers in the future.

When not in use, the coating chamber shall be sealed and purged to prevent contamination.

## 2.3 USER AND OPERATOR CHARACTERISTICS

The M2/M3 coating plant will be software-driven to ensure safe, repeatable application of high quality coatings. Experienced personnel who are trained in optical handling will be required to handle M2 and M3 while stripping, cleaning, loading and unloading the mirrors from the coating plant.

## 2.4 EXTERNAL INTERFACES

The M2/M3 Coating Plant will interface with the following subsystems:

Subsystem: M2S

- Interface Control Document: RD7
- Critical interface issues:
  - Mechanical interface between M2 and M2 Coating Fixture

Subsystem: M3S

- Interface Control Document: RD8
- Critical interface issues:
  - Mechanical interface between M3 and M3 Coating Fixture
  -

Subsystem: TMT Observatory Facilities

- Interface Control Document: TBD
- Critical interface issues:
  - Facilities must provide a Class 10,000 clean room arrangement to prevent dust from falling on optical surfaces after coating has been stripped and before segment is installed and sealed into coating plant.
  - The coating plant subsystem must work with Facilities to determine the location of vacuum chamber pumps and pressure control to ensure uniform vacuum conditions within the coating plant that will result in high quality, uniformly thick coating layer deposition.
  - Facilities must provide a supply of power, coolant, processing and source gases for coating plant function. The coating plant subsystem must identify the plant requirements and any safety issues related to coating materials storage, handling and stability.
  - TMT observatory requires environmental constraints on electromagnetic interference (EMI), vibration and thermal dissipation from the coating plant including pumps and compressors.
  - Required hardware (such as cranes) for loading and unloading the coating plant will be provided by the TMT Observatory Facilities subsystem. Interfaces must be developed between the coating plant subsystem and Facilities.

## 2.5 CONSTRAINTS

- a. Regulatory policies
  - Some coatings may require source materials that present potential hazards to personnel and equipment. The coating plant shall incorporate hardware and safety features to ensure the safety of personnel and equipment. The coating plant, all source materials and all coating byproducts must comply with local regulations regarding safe storage, handling, and disposition of dangerous materials.
- b. Hardware limitations
  - Any EMI, vibrations and heat introduced by the coating plant into the TMT observatory environment must be less than specified limits.
- c. Software limitations

- Since the coating deposition must be very repeatable, the software recipes for the coating must be password protected, robust and not be easily changeable or corruptible.
  - Since the coating deposition will be unique for this coating plant and mirror arrangement, the ability to adjust the process recipe to permit optimization of the resulting coating layer deposition must be provided.
  - Since the coating deposition recipe may change in the future, it must be possible to update the recipe to include changes. The software must be well documented to allow recipe changes when required.
- d. Audit (troubleshooting) functions
- In case of coating plant failure, troubleshooting functions shall be provided to enable identification of the failed components.
  - Safety features shall be provided to enable safe shut down of the coating plant in the event of any component failure or loss of power.

## 2.6 ASSUMPTIONS AND DEPENDENCIES

The coating plant for TMT shall be designed to reproduce the four-layer Gemini protected silver coating for first light operations. This document provides requirements that shall guide the deposition of a Gemini-like coating. In addition, the coating plant must be designed to allow for additional source materials so that it can be augmented in the future to provide a coating that is enhanced to provide improved reflectivity performance. The reflectivity requirements are dependent on the requirements of the instruments of the TMT Observatory. Changes in instrument requirements will change the reflectivity requirements for the coating and the specifications for the coating plant.

The current plan for maintenance of the M2 and M3 coatings is frequent CO<sub>2</sub> snow cleaning and fluid washing, along with stripping and recoating every two years. It is a goal to have the coatings last for 5 years between reapplying coatings.

### 3. SPECIFIC REQUIREMENTS

#### 3.1 GENERAL CONSTRAINTS

[REQ-2-M23CP-0110] The M2/M3 coating plant shall be compliant with international SEMI S2 standards.

#### 3.2 ENVIRONMENTAL CONSTRAINTS

[REQ-2-M23CP-0210] The M2/M3 coating plant shall operate at the manufacturer's facility and at any elevation between sea-level and 4200 meters with correct values for system pressure measurements and full functionality.

*Discussion: The coating plant shall be fully tested and shall produce coated samples that meet the requirements described herein while at the manufacturer's facility and then after installation and commissioning at any TMT Observatory facility. The change in elevation between locations shall cause no degradation in performance of the coating plant.*

*Discussion: Pressure gauges may be recalibrated upon arrival at the TMT Observatory if necessary.*

[REQ-2-M23CP-0220] During daytime coating operations, the M2/M3 coating plant shall dissipate no more than an average of 44 kW of heat per day to the air and no more than an average of 17 kW of heat per day to facility coolant.

*Discussion: The M2 and M3 mirrors are recoated when the telescope is disassembled and the observatory is not operating, so heat dissipation is not critical.*

*Discussion: The dissipation power levels are from RD12.*

#### 3.3 FUNCTIONAL REQUIREMENTS

##### 3.3.1 Coating Chamber Requirements

[REQ-2-M23CP-0310] The coating plant shall coat the M2 and M3 mirrors with a coating that meets the performance specified in Table 2 and in RD1, in the order and with the thicknesses described in Table 3.

*Discussion: At first light, this coating shall be based upon the Gemini 4-layer protected silver coating. The coating plant shall be able to deposit NiCrN, Ag, and SiN<sub>x</sub> in the order described in Table 3 with the thicknesses described with the smoothness, uniformity and precision required.*

[REQ-2-M23CP-0312] During mirror coating, the coating chamber shall have the vacuum pumping capability to reach and maintain a pressure as low as  $1 \times 10^{-7}$  torr within a period of time sufficient to meet the throughput requirements.

*Discussion: This low pressure is used to remove contaminants from the coating chamber prior to deposition.*

[REQ-2-M23CP-0314] The coating plant shall have capacity for upgrading the coating recipe to enhance the coating performance to meet the goals specified herein. The provision for upgrade shall include the addition of up to three additional ports for sources and associated power lines, gas lines and coolant plumbing to enable process variation.

*Discussion: The additional gas lines shall include MFCs, and isolation and control valves. The additional ports and gas lines shall be purged with inert gas and sealed upon delivery of the hardware.*

[REQ-2-M23CP-0316] Any reactive gas lines shall have the capability to be purged with inert gas and evacuated.

[REQ-2-M23CP-0318] Sensors must be incorporated in the design to monitor the thickness of the deposited layers.

[REQ-2-M23CP-0319] The invar pads bonded to the back of M2 and M3 shall not reach temperatures > 80°C. The low CTE glass or glass ceramic of M2 and M3 shall not reach temperatures > 100°C.

### 3.3.2 M2 and M3 Coating Fixture Requirements

[REQ-2-M23CP-0320] The coating fixtures for both mirrors shall protect the mirrors from damage, interface with the coating chamber loader, and shall not cover any portion of the mirror clear aperture for either mirror.

### 3.3.3 Coating Plant Controls Requirements

[REQ-2-M23CP-0330] The coating plant shall be instrumented to permit automatic segment cleaning and coating deposition.

*Discussion: The mirrors shall be manually loaded through the chamber loading port using the loader and loading port shall be manually closed. Following closing the chamber loading port, the baking, cleaning, and coating layer deposition shall proceed automatically.*

[REQ-2-M23CP-0332] Sensors shall be incorporated into the design of the coating plant so that coating thickness, maintenance and functionality can be monitored and stored automatically.

[REQ-2-M23CP-0334] In case of coating plant failure, troubleshooting functions shall be provided to enable identification of the failed components.

### 3.3.4 Coating Plant Software Requirements

[REQ-2-M23CP-0340] The software controlling the coating plant shall be PLC-based with a user-friendly PC-supported graphical user interface.

[REQ-2-M23CP-0342] The software shall be recipe driven with password protection to prevent inadvertent recipe modification.

[REQ-2-M23CP-0344] Coating data shall be collected and stored automatically for each coating run.

[REQ-2-M23CP-0366] The control software shall have an Ethernet data pipeline to enable remote access to process data and system status.

*Discussion: Coating plant functionality and safety shall be monitored with a safety system that will be described in Paragraph 3.5.3.*

### 3.3.5 Process Throughput

[REQ-2-M23CP-0350] The coating plant shall be capable of depositing the 4-layer protected silver Gemini coating, or an advanced 6-layer coating within a 24 hour period, including pump-down, bake-out, cleaning, and deposition.

### 3.4 COATING PERFORMANCE REQUIREMENTS

*Discussion: The coating performance requirements are detailed in RD1 and are listed in Appendix I below.*

### 3.5 SYSTEM ATTRIBUTES

[REQ-2-M23CP-0500] The coating plant shall interface with the TMT coating laboratory facility with the loading port opening into the clean room area, a seal between the loading port and the rest of the coating plant, and the remaining portion of the coating plant located in the Service Area.

*Discussion: The loading port protrudes into the clean room, while the remainder of the coating plant resides in the Service Area. The coating plant has a collar that interfaces with the clean room wall, forming a seal at the transition to the loading port.*

[REQ-2-M23CP-0502] The roughing pumps and cryopump compressors shall be vibration isolated and located in an adjacent pump room that is located TBD meters from the coating plant.

[REQ-2-M23CP-0504] The TMT coating laboratory facilities shall supply the facilities listed in Table 4 for the coating plant use.

[REQ-2-M23CP-0506] The coating plant shall be sized to fit within the shared volume shown in Figure 4 with adequate area around the coating plant to provide access for all maintenance and repair activities. The M2 and M3 coating plant will share the service volume with the M1 segment coating plant which must be accommodated.

Table 4. Coating Plant Facilities Interface Definition

Feature	Requirement (TBC)
Power	400 Amps, 120Y208 V/ 3 phase, 60 Hz
Cryopump Power	100W, and has a 1.14A current draw per pump
Coolant	Water: temperature: 20 to 25°C, up to 20 gpm @ 65 psig
Nitrogen	100 psig
Clean Dry Air	100 psig
Argon	TBD liters per minute during coating deposition

#### 3.5.1 Reliability

[REQ-2-M23CP-0510] The coating plant shall be designed to operate with regular maintenance and repair as required for 50 years.

[REQ-2-M23CP-0512] The coating plant shall be designed so that failure and maintenance are not required during an annual coating run.

*Discussion: The M2/M3 coating plant shall be used once per year, typically. Prior to use, it shall be possible to service and test all systems to assure reliable operation during the coating run.*

[REQ-2-M23CP-0514] The coating plant design shall include sensors to monitor maintenance requirements and safety issues.

### 3.5.2 Availability

[REQ-2-M23CP-0520] Any components that require replacement shall either be readily available with vendor and part number supplied or shall be provided as spares upon delivery of the coating plant.

### 3.5.3 Safety and Security

[REQ-2-M23CP-0530] Alarms, interlocks and sensors shall be incorporated in the design of the coating plant to monitor unsafe conditions, produce appropriate alarms, and automatically shut down the coating plant safely.

[REQ-2-M23CP-0532] In the event of any component failure or power loss from any reason, the safety system shall enable safe shut down of the coating plant to protect personnel, mirrors and the coating plant.

[REQ-2-M23CP-0534] The coating plant shall have an emergency stop (E-Stop) switch that will place the equipment into a safe shutdown condition when activated. Said E-Stop shall not be linked to the Observatory safety systems.

[REQ-2-M23CP-0536] The coating plant shall be designed with features that protect the mirrors from damage in the event of any mechanism or control system failure.

*Discussion: The system shall be fail-safe. No single point failure shall result in damage to the mirrors.*

### 3.5.4 Maintainability

[REQ-2-M23CP-0540] The coating plant shall be designed to facilitate servicing, by providing access to all subsystems, with the ability to remove and replace components that might require service or replacement.

[REQ-2-M23CP-0542] A detailed Service Manual describing the function of the coating plant, the components, replacement, upgrading, repair and maintenance shall be delivered along with the coating plant.

[REQ-2-M23CP-0544] As much as possible, maintenance of the coating plant shall be planned to take place with access from the Service Area. Only when necessary for loading port and loader maintenance shall maintenance take place with access from the clean room area.

### 3.5.5 Seismic Safety

[REQ-2-M23CP-0550] The M2/M3 Coating Plant and all subsystems shall withstand earthquakes up to the levels of a 10-year return period earthquake without injury to personnel, a mirror segment that is contained within the coating plant, or the coating plant. The system shall be designed to TBDg horizontal, and TBDg vertical quasi-static loads assumed to act independently, in addition to gravity and atmospheric pressure. Particular attention shall be paid to the management of hazardous gases. It shall be possible for the coating operations staff to perform an inspection of the system within 8 hours after said earthquake. The inspection shall be sufficient to ensure the coating plant is in a safe condition to allow resumed coating operations to take place.

*Discussion: Inspection would be expected to start after any potentially damaging event once the danger has passed and staff have returned to work.*

[REQ-2-M23CP-0551] The M2/M3 Coating Plant and all subsystems shall withstand earthquakes up to the levels of a 200-year return period earthquake without injury to personnel, damage to a mirror segment that is contained within the coating plant, with coating plant damage limited to \$100,000 (2009 US Dollars) in value. The system shall be designed to +/-TBDg horizontal, and +/-TBDg vertical quasi-static loads, assumed to act

independently, in addition to gravity and atmospheric pressure. Particular attention shall be paid to the management of hazardous gases. After inspection and repair, coating plant shall be capable of resumed coating operation within 12 weeks.

[REQ-2-M23CP-0552] The M2/M3 Coating Plant and all subsystems shall withstand earthquakes up to the levels of a 1000-year return period earthquake without injury to personnel, damage to a mirror segment that is contained within the coating plant, with coating plant damage limited to \$200,000 (2009 US Dollars) in value. The system shall be designed to +/-TBDg horizontal, and +/-TBDg vertical quasi-static loads, assumed to act independently, in addition to gravity and atmospheric pressure. Particular attention shall be paid to the management of hazardous gases.

[REQ-2-M23CP-0553] The coating plant shall be equipped with an accelerometer and control system that will shut down the coating plant in a safe manner should accelerations exceed 0.1g(TBC) in any direction.

[REQ-2-M23CP-0554] The coating plant and associated equipment shall be securely mounted to the floor of the facility to prevent overturning in the event of an earthquake. Such mounting shall be compatible with vibration isolation required per [REQ-2-M23CP-0502].

## APPENDIX

### I. REQUIREMENTS FOR REFLECTIVE OPTICAL COATINGS, FROM RD2

*Discussion: This section includes requirements from **Error! Reference source not found.**, AD2, and RD1.*

#### a. PERFORMANCE REQUIREMENTS

##### i. Reflectivity Requirements

[REQ-2-CO-1100] The reflectivity of a freshly applied coating for M1 segments, M2 and M3 at first light shall equal or exceed the values given in the Requirement column of Table 5 for the wavelength bands specified.

Table 5. Minimum reflectivity as a function of wavelength for fresh coatings at the prescribed angles of incidence shown in Table 6.

Range	Requirement	Goal
0.31 - 0.34 $\mu\text{m}$	N/A	0.8
0.34 - 0.36 $\mu\text{m}$	0.8	0.9
0.36 - 0.40 $\mu\text{m}$	0.8 $\rightarrow$ 0.9	0.9 $\rightarrow$ 0.95
0.4 - 0.5 $\mu\text{m}$	0.9 $\rightarrow$ 0.95	0.95 $\rightarrow$ 0.98
0.5 - 0.7 $\mu\text{m}$	0.95 $\rightarrow$ 0.97	0.98
0.7 - 1.8	0.97	0.98
1.8 - 28 $\mu\text{m}$	0.97	0.98

*Discussion: An arrow in the Requirement column indicates that the reflectivity requirement in that range varies linearly from the first value specified at the lower end of the wavelength range to the second value specified at the higher end of the wavelength range.*

*Discussion: This distribution of reflectance is nearly met by the performance of the Gemini protected silver coating as reported in RD8.*

[REQ-2-CO-1102] The reflectivity of a freshly applied coating as a function of wavelength presented in Table 5 shall diminish <0.5% as the angles of incidence change across the mirror element surfaces over the ranges shown in Table 6.

Table 6. Range of angles of incidence for reflection at each mirror surface.

Mirror Element	Angles of Incidence	
	Minimum	Maximum
<b>M1 Segment</b>	0°	14.4°
<b>M2</b>	0°	14.1°
<b>M3</b>	32°	48°

[REQ-2-CO-1103] For fresh new coatings, the reflectance of the coating at a single angle of incidence over the surface of the coated element over the wavelength range from 0.31 to 28  $\mu\text{m}$  shall be uniform within the following limits:

M1 segments:

$\pm 0.3\%$  across the segment surface averaged from discrete measurements of roughly 10 mm diameter spots

M2:

$\pm 0.3\%$  across the element surface averaged from discrete measurements of roughly 10 mm diameter spots

M3:

$\pm 0.2\%$  across the element surface averaged from discrete measurements of roughly 10 mm diameter spots

### ii. Emissivity Requirements

[REQ-2-CO-1200] The emissivity of a freshly applied coating for M1 segments, M2 and M3 at first light, over the wavelength range of 0.7 to 28  $\mu\text{m}$ , shall be less than or equal to 0.015.

*Discussion: The performance of the Gemini coating complies with this requirement per RD8.*

*Discussion: As a goal, the emissivity of each surface should be less than 0.013.*

### iii. Change of reflectivity with wavelength

[REQ-2-CO-1300] The variation of reflectivity of the coating with wavelength shall be less than 0.003 per nm of wavelength.

### iv. Polarization

[REQ-2-CO-1400] The phase shift of light shall be less than 22° when reflected with an angle of incidence of 45° off a freshly coated optical surface.

*Discussion: The performance of the Gemini coating complies with this requirement per RD8.*

### v. Coating thickness uniformity

[REQ-2-CO-1500] The optical surface figure change of the M1 segments, due to total coating thickness non-uniformity, shall be segregated into two types: correctable and non-correctable. The correctable low spatial frequency thickness variation up to Zernike 3<sup>rd</sup> order shall be less

than 50nmRMS (TBC). The non-correctable thickness variation for 4<sup>th</sup> order and above shall be less than 5nm RMS (TBC)

Discussion: The M1 segments have active supports that are able to correct low-spatial-frequency shape errors up to and including 3<sup>rd</sup> order Zernikes. Shape errors having spatial frequencies above 3<sup>rd</sup> order are not correctable by the supports, and therefore they impact performance more significantly.

[REQ-2-CO-1501] The optical surface figure change of the M2 and M3, due to total coating thickness non-uniformity, shall be segregated into two types: correctable and non-correctable. The correctable low spatial frequency thickness variation up to Zernike 3<sup>rd</sup> order shall be less than 50nmRMS (TBC). The non-correctable thickness variation for 4<sup>th</sup> order and above shall be less than 5nm RMS (TBC)

Discussion: The M2 and M3 low-spatial frequency errors are correctable by reshaping the M1 to compensate. Higher-spatial frequency errors are not correctable on the M1 and therefore they impact performance more significantly.

#### vi. Coating-induced deformation of optical surface

[REQ-2-CO-1600] For the M1 segments, the allowable amount of repeatable defocus of the optical surface from coating-induced stress shall not exceed 200 nm peak-to-valley.

[REQ-2-CO-1602] Relative to the average optical surface defocus of all the M1 segments caused by coating-induced stress, the optical surface defocus of any individual segment shall not deviate by more than 40 nm peak-to-valley.

[REQ-2-CO-1604] For the M1 segments, the allowable amount of optical surface deformation, described by Astigmatism, Coma, and Trefoil, from coating-induced stress shall not exceed 20 nm peak-to-valley.

[REQ-2-CO-1605] For the M1 segments, the allowable amount of optical surface deformation, described by 4<sup>th</sup> order Zernikes and higher, from coating-induced stress shall not exceed 5 nm peak-to-valley.

[REQ-2-CO-1606] For the M2, the allowable amount of repeatable defocus of the optical surface from coating-induced stress shall not exceed 200 nm peak-to-valley.

[REQ-2-CO-1608] For the M2, the variation in defocus of the optical surface from coating-induced stress, from one coating application to the next, shall not exceed 100 nm peak-to-valley.

[REQ-2-CO-1610] For the M2, the allowable amount of optical surface deformation, described by Astigmatism, Coma, and Trefoil, from coating-induced stress shall not exceed 40 nm peak-to-valley.

[REQ-2-CO-1611] For the M2, the allowable amount of optical surface deformation, described by 4<sup>th</sup> order Zernikes and higher, from coating-induced stress shall not exceed 5 nm peak-to-valley.

[REQ-2-CO-1612] For the M3, the allowable amount of repeatable defocus of the optical surface from coating-induced stress shall not exceed 400 nm peak-to-valley.

[REQ-2-CO-1614] For the M3, the variation in defocus of the optical surface from coating-induced stress, from one coating application to the next, shall not exceed 200 nm peak-to-valley.

[REQ-2-CO-1616] For the M3, the allowable amount of optical surface deformation, described by Astigmatism, Coma, and Trefoil, from coating-induced stress shall not exceed 80 nm peak-to-valley.

[REQ-2-CO-1617] For the M3, the allowable amount of optical surface deformation, described by 4<sup>th</sup> order Zernikes and higher, from coating-induced stress shall not exceed 5 nm peak-to-valley.

*Discussion: Neither the final coating nor the coating process shall induce excessive non-uniform stress (surface warping) in mirror substrates, in excess of the optical uniformity requirement. Some defocus is acceptable, provided it is repeatable from segment to segment.*

#### vii. Coating process constraints

[REQ-2-CO-1700] At no time during the coating process shall the temperature of any portion of the glass or glass ceramic mirror substrate exceed 100° C.

*Discussion: This is to ensure dimensional stability of the substrate*

[REQ-2-CO-1702] At no time during the coating process shall the temperature of the adhesive used to bond attachments to the back surface of the glass or glass ceramic substrate exceed 80° C.

*Discussion: This is to ensure stability of the adhesive.*

[REQ-2-CO-1704] The coating deposition shall be compatible with a coating plant that can achieve a base pressure of  $1 \times 10^{-7}$  torr with the optic loaded and pumped down..

*Discussion: For example, contamination of silicon nitride layers with oxygen and H<sub>2</sub>O is a concern. Pumping down to lower than  $3 \times 10^{-7}$  torr has been recommended.*

[REQ-2-CO-1706] The deposition rate for the silver layer shall be high enough to avoid a reduction in reflectivity caused by surface plasmons.

*Discussion: Rates higher than 2 nm per second have been recommended.*

#### viii. Coating Durability

[REQ-2-CO-1800] The coating shall meet the performance requirements specified herein, during normal operation, for a period of no less than two years (5 years as a goal) when maintained using the cleaning methods and frequencies specified in 3.2.3.

### b. ENVIRONMENTAL, CHEMICAL AND PHYSICAL CONSTRAINTS

#### i. Coating Visual Inspection

[REQ-2-CO-2100] Visual inspection shall be performed per MIL-C-48497 Revision A, Section 4.5.2.5.2.

[REQ-2-CO-2102] The freshly applied coatings shall have no pinholes larger than 10 µm in diameter, fewer than 5 pinholes that are approximately 5-10 µm in diameter, and fewer than 5 pinholes that are < 5 µm in diameter within any 30mm x 30 mm area within the clear aperture of the coated substrate as determined by visual inspection.

*Discussion: As stated in RD11, section 4.5, pinholes are caused by dust on the surface during coating deposition. By keeping the coating chamber and mirror substrates free of dust, the pinholes in the coating will be minimized. The facility for coating TMT mirrors will have a clean room at the coating plant load/unload stations.*

*Discussion: The pinhole size and quantity listed above are from RD11 and were obtained during Gemini coating deposition when the substrate was blown clean using CO<sub>2</sub> snow as it was installed into the coating chamber. In addition, the coating chamber was outfitted with a HEPA-filtered air system and maintained at a positive pressure. The clean room approach adopted by TMT should improve the cleanliness conditions, thus should improve the pinhole size and*

frequency. The pinhole size and quantity affect the durability of the coating, thus should be minimized.

[REQ-2-CO-2104] The freshly applied coatings shall cover 100% of the clear aperture and shall have combined defects within the clear aperture <0.1% of the clear aperture area. The maximum size of any one single defect shall be <5mm<sup>2</sup>.

*Discussion: Defects are defined in MIL-C-48497 Revision A and shall also include stains, streaking, smears and other coating features that would affect the spectral response of the coated surface.*

*Discussion: The Gemini 4-layer coating passes this inspection.*

### ii. Environmental, Chemical and Physical Testing

[REQ-2-CO-2200] Five (TBC) witness samples made of the same substrate material as each mirror element, and prepared in the same manner, shall be coated along with each mirror element during every coating run, under process conditions identical to the conditions existing at the mirror surface. The witness samples will be labeled.

[REQ-2-CO-2202] TBD witness samples that were coated along with the mirror element shall pass the following tests, conducted in the order presented in **Error! Reference source not found..** The state of operation (defined per the ISO specification) is not applicable for all tests.

Table 7. Environmental, Chemical and Durability Testing of the Optical Coating

Description	Test Specification	Test pass criteria
Salt Mist: 5% NaCl solution at 35°C for 2 days	ISO 9022-40-05	no reflectivity loss
Damp Heat: 16 hours at 55°C 90%-95% relative humidity	ISO 9022-12-07	no reflectivity loss
Slow Temperature Change: 5 cycles from -10°C to 40°C, 2.5 hour dwell at each end, temperature change rate 0.2°C/minute	ISO 9022-14-01	no reflectivity loss
H <sub>2</sub> S exposure: 5 ppm at 35°C, 75% relative humidity, for 4 days	ISO 9022-42-08	>88% reflectivity at λ≤0.5μm, no reflectivity loss at λ> 0.5μm
Coating environmental durability test for Abrasion	ISO 9211-4-01-01	No scratches discernable
Coating environmental durability test for Adhesion	ISO 9211-4-02-02	No coating removal discernable

### iii. Maintainability

#### 1. Cleaning Maintenance

[REQ-2-CO-2310] The coating on M1 segments, M2, and M3 shall be capable of being cleaned with CO<sub>2</sub> snow at weekly intervals over a two-year period (104 cleaning processes total).

*Discussion: The proposed cleaning schedule is not dictated by throughput performance as much as by a desire to prevent dust and contaminants from adhering to the coating and reducing its lifetime per page 4 of RD10.*

[REQ-2-CO-2312] The coating on TMT M1 segments M2, and M3 shall be capable of being cleaned with fluids at monthly intervals over a five-year period (60 cleaning processes total). The fluids to be used may include water, water with detergent, alcohol (methanol and ethanol), and acetone.

*Discussion: The proposed cleaning schedule is not dictated by throughput performance as much as by a desire to prevent dust and contaminants from adhering to the coating and reducing its lifetime per page 4 of RD10.*

[REQ-2-CO-2314] After a two year period, the total reduction in reflectivity caused by all cleanings (CO<sub>2</sub> snow and fluid combined) shall be less than 2%.

*Discussion: Based on RD8, the Gemini coating experiences no discernible reflectivity, adhesion and durability change when exposed to the listed fluids. Figure 9 of RD11 indicates that the 4-layer Gemini coating meets this requirement.*

*Discussion: The reduction in reflectivity does not include the effect of dust collection over time. It is assumed that the cleaning removes the dust.*

## 2. Recoating Maintenance

[REQ-1-OCD-2320] The interval between M2 and M3 recoating events shall be no less than 24 months (TBC), i.e. it shall be possible to meet the mean net reflectivity requirement for at least 24 months based on M2 and M3 considerations alone. During the design phase, consideration shall be given to allowing M2 and M3 recoating to be completed within the same TBC window (goal: 5 days maximum).

[REQ-2-CO-2322] The coating shall be completely strippable with chemicals within an elapsed time of no more than two hours, with no damage to the underlying substrate.

[REQ-2-CO-2324] The chemicals required to strip the coating shall not be hazardous to personnel or equipment, though protective masking, respirator, and clothing may be required.

*Discussion: Materials used to strip Gemini coatings are Hydrochloric Acid and Ammonium Cerium Nitrate. Per RD8, these materials are able to strip the 4-layer Gemini coating within 30 minutes.*

[REQ-2-CO-2326] The M1 segment coating shall be designed so that substrate and chamber preparation and coating application can all be accomplished in less than 4 hours.

*Discussion: This allows the continuous processing of M1 segments to occur within normal working hour shifts during operations, and the coating of two segments per day during Assembly, Integration and Verification.*

[REQ-2-CO-2328] The coating shall be designed so that substrate and chamber preparation and coating application for the M2 and M3 can all be accomplished in less than 24 hours (three 8-hour shifts) with a goal of 16 hours.

*Discussion: This allows time for careful chamber preparation, mirror cell disassembly and large mirror handling steps while leaving 2 days worth of normal working hour shifts for installation and removal of the mirrors from the telescope.*

## iv. Safety and Health

[REQ-1-ORD-7000] The observatory shall comply with all applicable local and national safety regulations and standards.

[REQ-2-CO-2400] The TMT coating deposition and removal processes shall not endanger the health and safety of personnel, nor cause damage to the M1 segments, M2 and M3.

[REQ-1-ORD-7200] The observatory shall comply with all applicable local and national environmental and occupational health regulations and standards.