

## **1.0 Background Information**

---

### **1.1 TMT Design Overview**

A detailed description of the entire TMT Observatory is contained in the TMT Construction Proposal [Ref. 1]. The Construction Proposal is the essential document for understanding the TMT Project (TMT) and seeing where this Statement of Work fits into the objectives of TMT. The top-level requirements that define the Observatory are contained in the Observatory Architecture Document (OAD) [Ref. 2] and the Observatory Requirements Document (ORD) [Ref. 3].

### **1.2 Primary Mirror Overview**

The following brief overview of the Primary Mirror (M1) is intended as introductory. The listed references should be reviewed to gain a full understanding of the M1 system.

The TMT Primary Mirror [Figure 1] is composed of 492 segments and includes the following:

- 492 aspheric, hexagonal-shaped, polished and coated mirror segments mounted on passive/active segment support systems
- A steel mirror cell that supports the array
- The M1 Control System (M1CS) that maintains the alignment and phasing of the segments and controls the active support systems

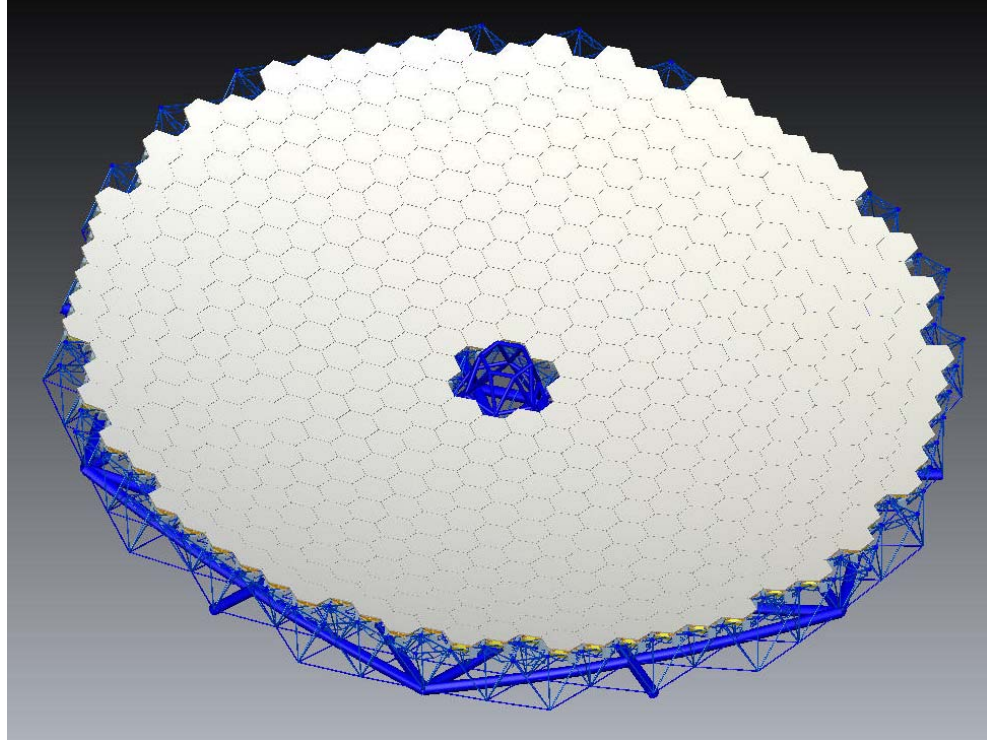

*Figure 1: Primary Mirror Array Attached to Mirror Cell Structure*

### **1.2.1 Segment Position Control**

Each mirror segment is hexagonal, nominally measuring 1.44m across the corners, and is passively supported in the three in-plane degrees of freedom by the Segment Support Assembly (SSA), and actively controlled in the out-of-plane degrees of freedom (Piston, Tip and Tilt) by the M1CS. The M1CS includes three segment position actuators per segment and six edge sensors per segment for position feedback (12 half-sensors are mounted on each segment). The edge sensors detect the relative position of the edges of adjacent segments. The SSA is the mechanism that connects the glass mirror segment to the steel mirror cell.

As the telescope changes elevation angle, the varying gravity vector causes small, millimeter-level, deformations of the mirror cell structure. The M1CS compensates for this disturbance, and other effects, by controlling the three active degrees of freedom of each segment, thereby maintaining the required optical surface shape of the M1.

### **1.2.2 Array Phasing and Surface Figure**

The Alignment and Phasing System (APS) will use starlight to provide feedback for aligning and phasing the segments. The relative positions of the segment edges will be measured by edge sensors so the shape of the primary mirror can be maintained for weeks by maintaining the same edge sensor readings. The APS will also provide information about the optical figure of each segment. Each SSA incorporates a warping harness system that is capable of changing the optical figure of the segment. Using the APS measurements, the M1CS will be

able to command the warping harness to correct low-order segment aberrations such as focus and astigmatism by adjusting the set of 21 motorized moment actuators on each segment.

**1.2.3 Segmentation**

There are gaps between segments to prevent them for contacting under any circumstance. The gaps are nominally a uniform 2.5mm wide, chosen to maximize collecting area. Given this constant gap width, it is necessary to vary the size and shape of the hexagons to allow them to fit the aspheric optical surface. It was decided that the array of 492 segments should be broken into six identical sectors, each having 82 unique segments as shown in Figure 2. The segments are unique in both hexagonal shape and optical prescription. Within the array, each set of 82 is interchangeable from one sector to another (note that the segments must be rotated by a multiple of 60 degrees when moved from one sector to another). The geometry of the segments is contained in the Segmentation Database [Ref. 4], which defines the coordinates of each of the 82 segment vertices, and a number of other key dimensions for each segment.

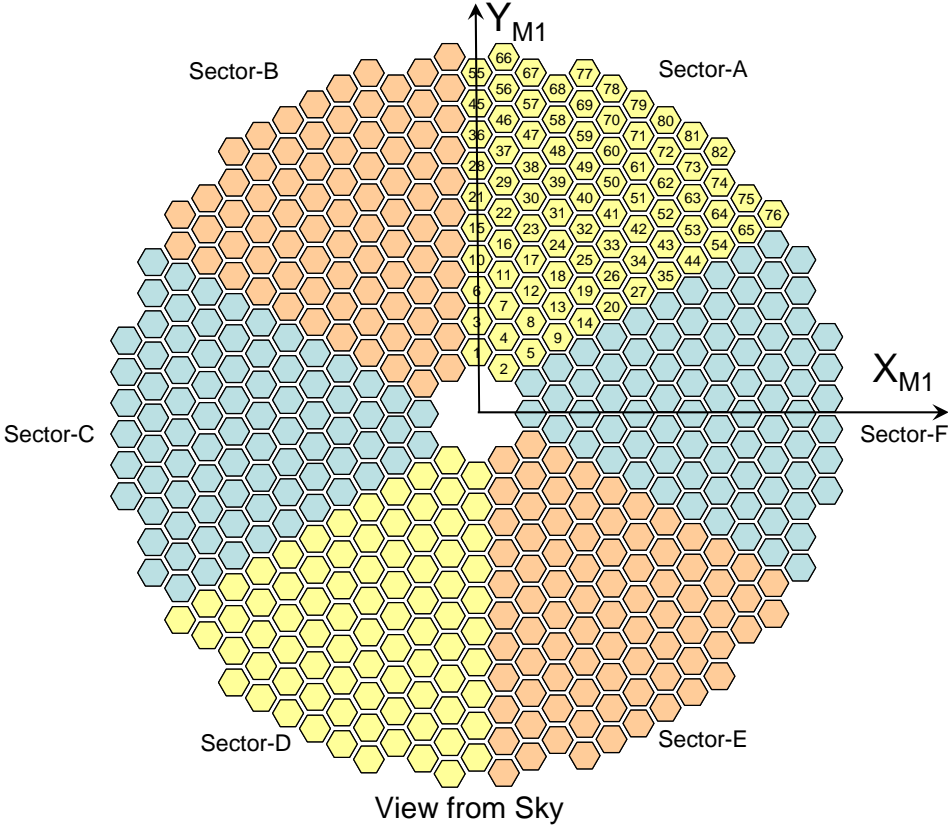

Figure 2: M1 Segmentation Pattern showing Sectors (A-F) and Segment Types (1-82)

The Observatory requires 574 Polished Mirror Assemblies (PMAs), corresponding to seven sets of the 82 unique segments. Six of these sets are installed in the array at any one time (492 segments), while the seventh set of spare segments is cycled through the array during the routine re-coating process.

### 1.2.4 Segment Support Assembly

To achieve the required surface accuracy and stability each segment will be supported by a passive support system consisting of nearly-independent axial and lateral support systems. The axial support system is a 27-point whiffletree, and the lateral support employs a central diaphragm. Figure 3 shows a Primary Segment Assembly (PSA) installed on the top-chord members of the mirror cell. For simplicity, only three top-chord members are shown, in reality the mirror cell is a network of many such members. The PSA includes the PMA and the Subcell. Also shown in the figure are the segment position actuators and the edge sensors. The Polished Mirror Assembly is shown in Figure 4 and the Subcell installed in the mirror cell is shown in Figure 5.

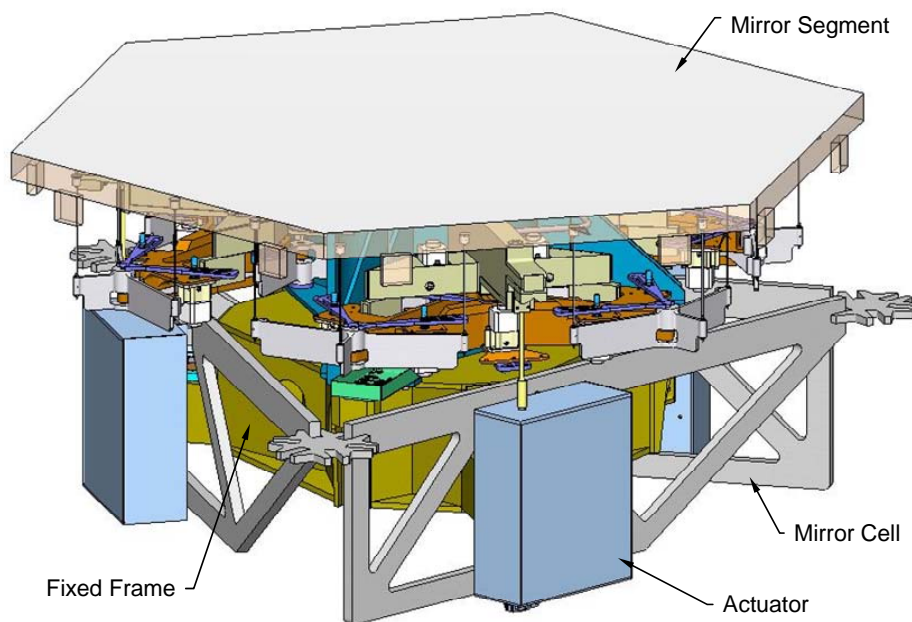

Figure 3: Primary Segment Assembly (PSA) mounted to Mirror Cell with Actuators

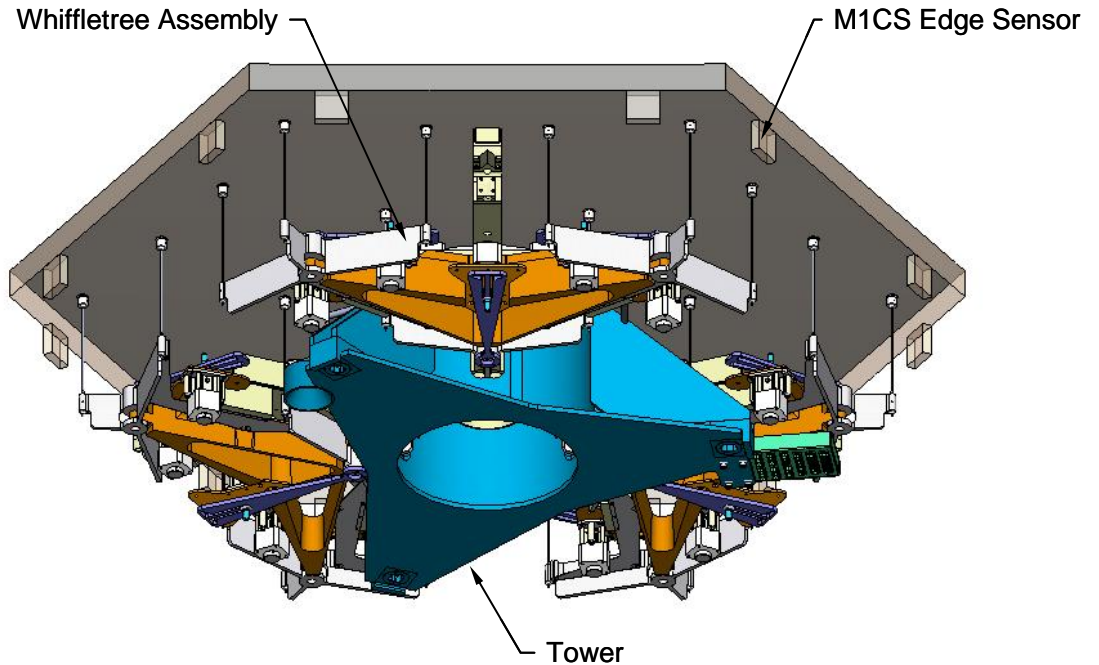

Figure 4: Polished Mirror Assembly (PMA) with edge sensors

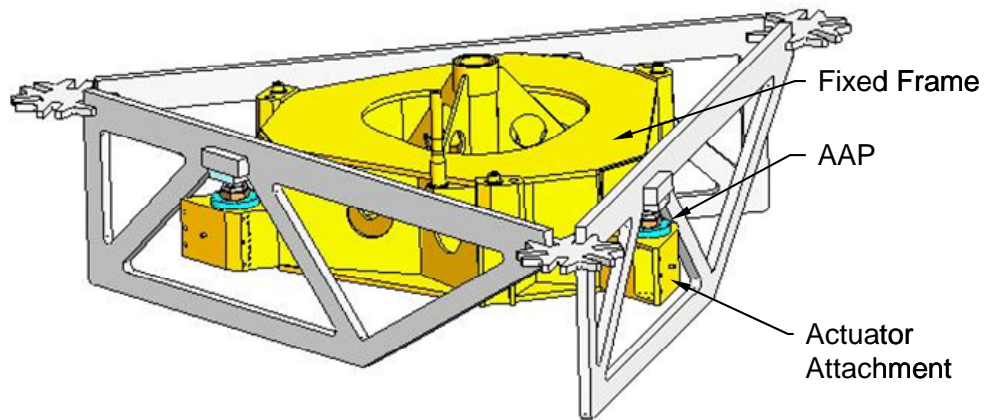

Figure 5: Subcell installed in the Mirror Cell Top Chord

The SSA design concept is shown schematically in Figure 6. Key features within the SSA are:

- The 27 point, two level whiffletree-based axial support system
- The Central Diaphragm lateral support system located in a pocket bored into the back of the mirror segment.
- The Moving-Frame structure that provides a stiff intermediate platform for the axial and lateral supports to ride on. The moving frame is supported in-plane by the guide-flexure, and out-of-plane by the segment position actuators.

- The Tower structure connects the guide flexure (and hence the moving frame) to the Fixed Frame.
- The Polished Mirror Assembly, (PMA) represents everything from the tower upwards, (it does not include the Fixed Frame or Adjustable Alignment Positioners). The PMA is removable from the Telescope for re-coating and servicing. There is a repeatable interface between the base of the Tower and the Fixed Frame so that the PMAs can be removed, replaced or exchanged without in-plane re-alignment.
- The Fixed Frame is a permanently installed structure that is attached to the mirror cell and accurately aligned. The PMA and actuators mount to the Fixed Frame. Due to segmentation, there are two versions of the Fixed Frame. One version fits sectors A, C, and E, while the other version fits in sectors B, D and F which are rotated 60 degrees in-plane relative to sectors A, C and E.
- The Adjustable Alignment Positioners (AAPs) are the connection between the Fixed Frame and the Mirror Cell. The AAPs permit several millimeters of relative motion between the Fixed Frame and the mirror cell during Subcell alignment. The Fixed Frame and the set of three AAPs are called the Subcell. The Warping Harness System is an active-optic control system that enables the removal of low-order aberrations from the finished segments. The corrections are made by introducing a set of prescribed bending moments at the joints of the whiffletrees, which force the mirror into the desired shape. The mechanisms include a set of 21 instrumented leaf-springs which are acted upon by an equal number of motorized actuators. Since the Warping Harness actuators are motorized and instrumented they can be operated remotely.

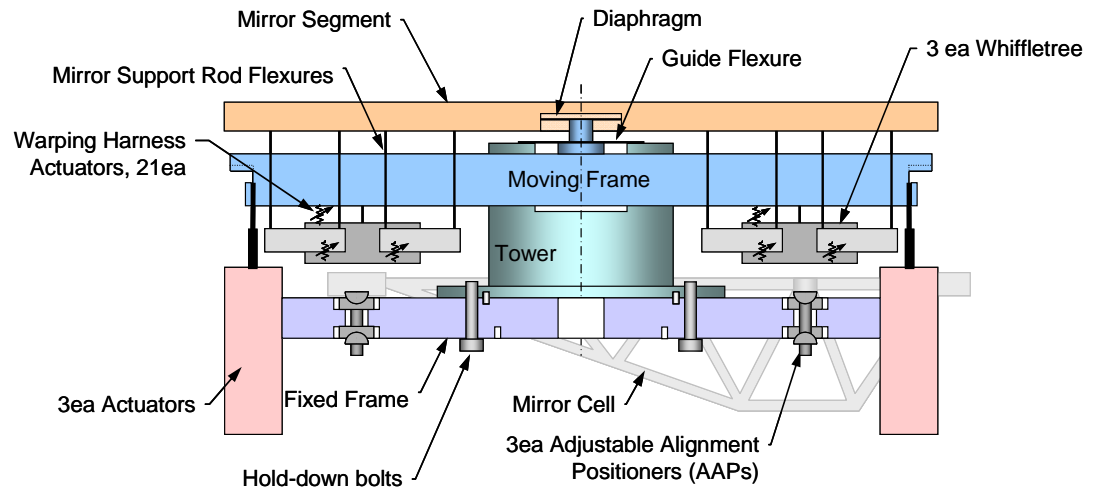

Figure 6: Schematic of the Segment Support Assembly (SSA) in the Mirror Cell

### 1.2.5 Segment Figuring

As described in the Specification for Finished Primary Mirror Segments [Ref. 5], the mirrors are final figured after they are mounted to the support system. They are acceptance tested with the normal to the optical surface ( $Z_{SCRS}$ ) pointing

upwards, at the mean observing temperature. The specification does permit the optical testing to be conducted at a higher temperature, if the Contractor can demonstrate that results reliably predict the performance at the mean observing temperature. This manufacturing sequence makes it possible to figure-out any surface errors introduced by the assembly process, such as pre-stress, thermal distortion, and adhesive cure shrinkage at the attachments to the glass. Furthermore, the distortion due to axial gravity can also be eliminated for this segment inclination.

### **1.2.6 Segmentation Correction**

Since the segmentation pattern results in segment shapes that are not regular or identical, it is necessary to compensate for these small, millimeter-level, variations in the design of the support system. If uncorrected, these variations would result in imbalances in the whiffletrees that would produce unacceptably large surface errors as the segment zenith angle is varied.

TMT has elected to compensate for these segmentation effects by re-balancing each of the 82 types of whiffletrees. The re-balancing is accomplished by fabricating each unique whiffletree set with small internal adjustments that alter slightly the location of the joints. Given this approach, there are 82 unique types of whiffletree sets, each of which is mated to the corresponding mirror segment type during segment production.

### **1.2.7 M1 Array Integration Process and Timeline**

The integration of the M1 segments onto the telescope will occur during the Assembly Integration Verification (AIV) phase. The sequence of these activities is described briefly to provide background for understanding the hardware delivery schedule.

The 492 PSAs must be installed into the mirror cell and aligned with great precision and care. If segments are not properly positioned within the array, there will be large optical errors introduced into the shape of the M1 array. It is the location of the Fixed Frames that defines the position of the segments in the array, so the process of Subcell alignment is critical. Since the segments are not yet installed when the Subcells are aligned, it is necessary to mass-load the mirror cell using dummy masses attached to each Fixed Frame so that the mirror cell is statically deformed into the operational shape during alignment.

A set of three surveying targets shall be temporarily affixed to each Fixed Frame to permit positional measurement with the Global Metrology System (GMS). The surveying targets are held in place by a temporary structure called a target holder. The target holders attach to the Fixed Frame at the same three registration features where the PMA normally attaches.

The PMAs are shipped from the Polisher facility to the Observatory uncoated. When they arrive at the Observatory, they are unpacked from their shipping containers and then coated, at a rate of two segments per day. After coating, the segments are stored until such time as they can be installed into the telescope.

The schedule for these operations is constrained by the availability of the Coating Plant and by a finite amount of segment storage space at the observatory. Because of these realities, it is anticipated that the polisher will likely have produced approximately 350 segments prior to the first shipment. Subsequent shipments are to be made at a rate that sustains the desired rate of segment coating and installation at the Observatory.

During AIV the segments will be installed into the M1 array as described below. The delivery schedule for the PMAs shall support this objective.

- The first segments to be installed will be a contiguous cluster of segments within one or two sectors near the inner diameter of the M1. These first segments will be of Segment Type  $\leq 44$ . The starlight reflected off the segments will be incident on a Prime Focus Camera.
- Building from this cluster, additional segments will be added until the innermost 8 rings of hexagonal segments are populated (The first ring contains segment types 1 and 2, the second ring contains Types 3-5, the third ring contains Types 6-9, etc.). At this stage Segments 1-44 will be installed in each of the six Sectors.
- Subsequently, installation will proceed radially outward until all 492 segments are installed.
- The seventh set of 82 PMAs (the spare segments) may be delivered after the delivery of the first six sets.

In general terms, the M1 integration sequence is as follows:

#### Subcell Delivery

- The 492 Subcells, handling equipment, and tooling are delivered to the Observatory

#### Subcells and Dummy Masses Mounted on Mirror Cell

- The 492 Subcells are installed onto the mirror cell and initially located in their nominal positions (mid-range of the AAP adjustment range)
- The 492 dummy masses are installed on the Subcells to produce the statically deflected shape of the mirror cell

#### Subcell Surveying

- The surveying targets are installed on the Subcells and their positions are measured over a range of zenith angles
- A best-fit solution is calculated that determines the optimal position of each Subcell.

#### Subcell Alignment

- Each Subcell is then positioned in 6 degrees of freedom and locked permanently in the desired position within a specified tolerance
- Over a period of months, each dummy mass is removed and replaced by a mirror segment until the array is complete.

The AIV schedule requires that the first 492 segments be delivered to the Observatory as follows:

- 120 PMAs received in initial shipment, as specified in the SOW

- Followed by a minimum of 30 PMAs delivered per month during the subsequent 14 months

Segments cleaned, coated and installed in the array

- Segments received, cleaned, coated and staged for installation
- First 120 segments are installed in the array
- Remaining 372 segments are installed in the array at a rate of 30/month

The 82 spare PMAs are Delivery to Observatory within 1 year after the first 492 segments are delivered.

### **1.2.8 M1 Development Status**

Over the past several years, the TMT project, and its suppliers, have evolved many of the key system parameters and design concepts associated with the M1 Array, including:

- Telescope Optical Design [Ref. 2]
- Optical performance requirements subject to environmental and observing conditions [Ref. 3]
- The number, size, and precise shape of each of the mirror segments in the array [Ref.4] as well as a method for re-tuning the support system to compensate for these variations in segment shape and size.
- A Procurement Specification for the optical fabrication, polishing, figuring, and final acceptance testing of the Polished Mirror Assemblies (PMAs) [Ref. 5]
- A Procurement Specification for the Mirror Segment Blanks [Ref.6]
- The requirements and a detailed design for the Segment Support Assembly (SSA), which is now being prototyped by the supplier [Ref. 7]
- The configuration of the M1 Mirror Cell structure and the interfaces to the SSA
- The design of the interfaces between the M1CS Segment actuators and the SSA
- Concept designs have also been developed for the Subcell alignment tooling, segment lifting jack and segment lifting talon, and dummy masses used during integration [Ref 7].

## 2.0 References

---

1. **Thirty Meter Telescope Construction Proposal: TMT.PMO.MGT.07.009**  
File: TMT-Construction Proposal-Public.pdf
2. **TMT Observatory Architecture Document (OAD): TMT.SEN.DRD.05.002**  
File: OAD-CCR19.pdf
3. **TMT Observatory Requirements Document (ORD): TMT.SEN.DRD.05.001**  
File: ORD-CCR20.pdf
4. **TMT Segmentation Database: TMT.OPT.TEC.07.044**  
File: TMT M1 Segmentation Database REL02.txt
5. **Specification for Finished Primary Mirror Segments: TMT.OPT.SPE.07.002**  
File: TMT OPT SPE 07 002 CCR03 Specification for Finished Primary Mirror Segments.pdf
6. **Specification for Primary Mirror Segment Blanks: TMT.OPT.SPE.07.001**  
File: TMT OPT SPE 07 001 CCR06 – Specification for Primary Mirror Segment Blanks.pdf
7. **SSA PDR Volumes 1-7, TMT.OPT.PRE.07.056-63**  
File: HPS-280001-0105 - Volume-1 (EW,TMT M1 SSA PDR - OVERVIEW).ppt  
File: HPS-280001-0105 - Volume-2 (EW,TMT M1 SSA PDR - SYSTEM-LEVEL CALCULATIONS).ppt  
File: HPS-280001-0105 - Volume-3 (VS,TMT M1 SSA PDR - SYSTEM-LEVEL FEA).ppt  
File: HPS-280001-0105 - Volume-4 (EW TMT M1 SSA PDR – WARPING HARNESS).ppt  
File: HPS-280001-0105 - Volume-5 (EW TMT M1 SSA PDR - FLEXURES).ppt  
File: HPS-280001-0105 - Volume-6 (EW,TMT M1 SSA PDR - HANDLING & INTEGRATION).ppt  
File: HPS-280001-0105 - Volume-7 (EW,TMT M1 SSA PDR - SUMMARY & FUTURE PLANS ).ppt

### 3.0 Abbreviations and Acronyms

---

AAP:	Adjustable Alignment Positioner
AIV:	Assembly Integration Verification
APS:	Alignment and Phasing System
CAD:	Computer Aided Design
COTS:	Commercial Off The Shelf
CTE:	Coefficient of Thermal Expansion
e.g.	exempli gratia (for example)
GMS:	Global Metrology System
ID:	Inner Diameter
M1:	Primary Mirror
M1CS:	Primary Mirror Control System
N/A:	Not Applicable
OAD:	Observatory Architecture Document
OD:	Outer Diameter
ORD:	Observatory Requirements Document
PDR:	Preliminary Design Review
PMA:	Polished Mirror Assembly
PSA:	Primary Segment Assembly
Qty.	Quantity
Ref.	Reference
SSA:	Segment Support Assembly
TBC:	To Be Confirmed
TBD:	To Be Determined
TMT:	Thirty Meter Telescope
Yr.	Year